

LA48 – Linear Actuator – Specification Sheet

the LA Series of Linear Actuators by CTW Automation

the Technology Experts



when you need more than a sine wave....

LA48 - Key Specifications

- Fully Electric – Magnetic linear actuator for instant on motion and force
- Usable stroke range of 8+ inches / 200+ mm
- Peak force of 4,100 lbf. < > 18.24 kN
 - 4,000 lbf. out to 80 in/sec < > 2.00 Met/sec
 - 475 lbf. to 216 in/sec < > 5.50 Met/sec
 - Based on 240VAC power +/-2.5%
- Peak Velocity of 220 in/sec & 5.60 Met/sec
- Acceleration of 120+ G's peak & 30 G's continuous
- Frequency response above 200 Hz
- Optimized motion for cooler and quieter operation
- Sine, Sine-on-Sine, Square, Triangle, Split Velocity and track data and more
- Input power 208-240 VAC III phase – 60 A(i)

**All performance specs stated with 240VAC 60A 3phase input power. Performance specs are +/-10% unless otherwise noted.



The **LA Series** of actuators by CTW Automation is the ultimate in high performance linear motion that puts wave form creation and the resulting data collection at your fingertips; quickly, easily and in a repeatable fashion. While sine waves are standard, the LA allows for “any wave form” drive profiles allowing you to attain a better view into your testing world. From square, to triangle, sine on sine, frequency sweeps and stepped input; this platform lets you do it all. And because of the actuation methodology, coupled to the advanced motion controller, motion will be as requested and at a lower operating temperature and lower audible level.

Standard System Features:

Sensors and signals:

Displacement, Force and Temperature (via an infrared non-contacting sensor) are standard. **Velocity** is derived from Displacement giving (4) channels to be used in viewing the resulting data.

- Force / load is measure via Interface 5K Pancake design to ensure accurate and repeatable results with low noise rejection.
- Displacement comes from analog encoder of 1 nanometer resolution mounted to the actuator to deliver a true reading of motion in the vertical axis.
- Temperature is mounted on an easy to move, CTW custom quick clamp allowing the User to test any damper at a constant point helping to improve consistency in comparing dampers and changes.

Stroke:

The LA28/48/68 has a useable range of 8.00 inches & 200 mm as the maximum available movement is more thus allowing for a very usable stroke as well as additional travel outside the range.

Velocity:

The LA48 peak velocity is 220 in/sec & 5.6 M/sec. Owners should expect a very useful 5.50 Met/sec peak operating velocity with minimal displacement error within a given force range.

Acceleration:

Due to extreme design considerations in moving mass the acceleration performance far exceeds the industry norms. Over 120G's can be achieved for peak while a constant 30 G's is usable for testing. The frequency response is well over 175+ Hz at less than 3dB down.

Waveforms:

Wave forms include, but not limited to, Sine, Square, Triangle, Sine-on-Sine, Stepped and Pause function as well as Split-Velocity for separating compression and extension speeds. There will also be the potential for drive files to be imported so that you can replay displacement data from a track or event as well as white noise and other frequency generating wave forms.



Software:

By using a GUI based on Windows 10 application platform, you are ready to build your own Test sequences via command-based prompts that allow you to go from nothing to 200 Hz in a few moments. In standard configuration, the User has a wide variety of canned wave forms, logging and prompts to develop specific Tests for every given damper or test specimen.

- See website for additional information on software

Columns:

Columns are 2.00" diameter and standard length provides a test opening of 48" / 1220 mm from the end of the load cell stud to the top of the actuator. Longer columns can be purchased in additional 12" / 300 mm increments.

Power input:

The LA48 requires 208-240VAC III phase power of up to 60 A(i). Outside of North America, it is best to use a step-down transformer to go from 380/440 VAC III phase to the 240 VAC III. Power and controls are fed to the LA via a control cabinet interface.

* Note – for peak performance, three phase (III) – 60 Amps (i) and a high buss voltage up to 240 VAC should be supplied.

Training:

Training can be done on site or at Lexington facility. If CTW must travel, additional charges will result. Understand that the machine is done and ready when it leaves our dock so that it is possible to train in our facility knowing the machine will be easy to get running on site.

Support:

The LA28/48/68 comes with a 1 -Year phone and e-mail support contract as well as use of TeamViewer remote access ability for training and help. We want you to have every opportunity to use and get the most from the machine.

Warranty:

The LA28/48/68 comes with a 1 -Year limited warranty on any item based on failure outside of user misuse.

Delivery:

- Customer can opt to pick-up in Lexington, NC but then NC State tax applies
- Crate – (1) or (2)
- Shipping – to be determined
 - By ground transport in Continental US
 - International air freight shipping is preferred
 - If machine goes by ocean freight and additional charge will be accessed for salt exposure protection

LA28 / LA48

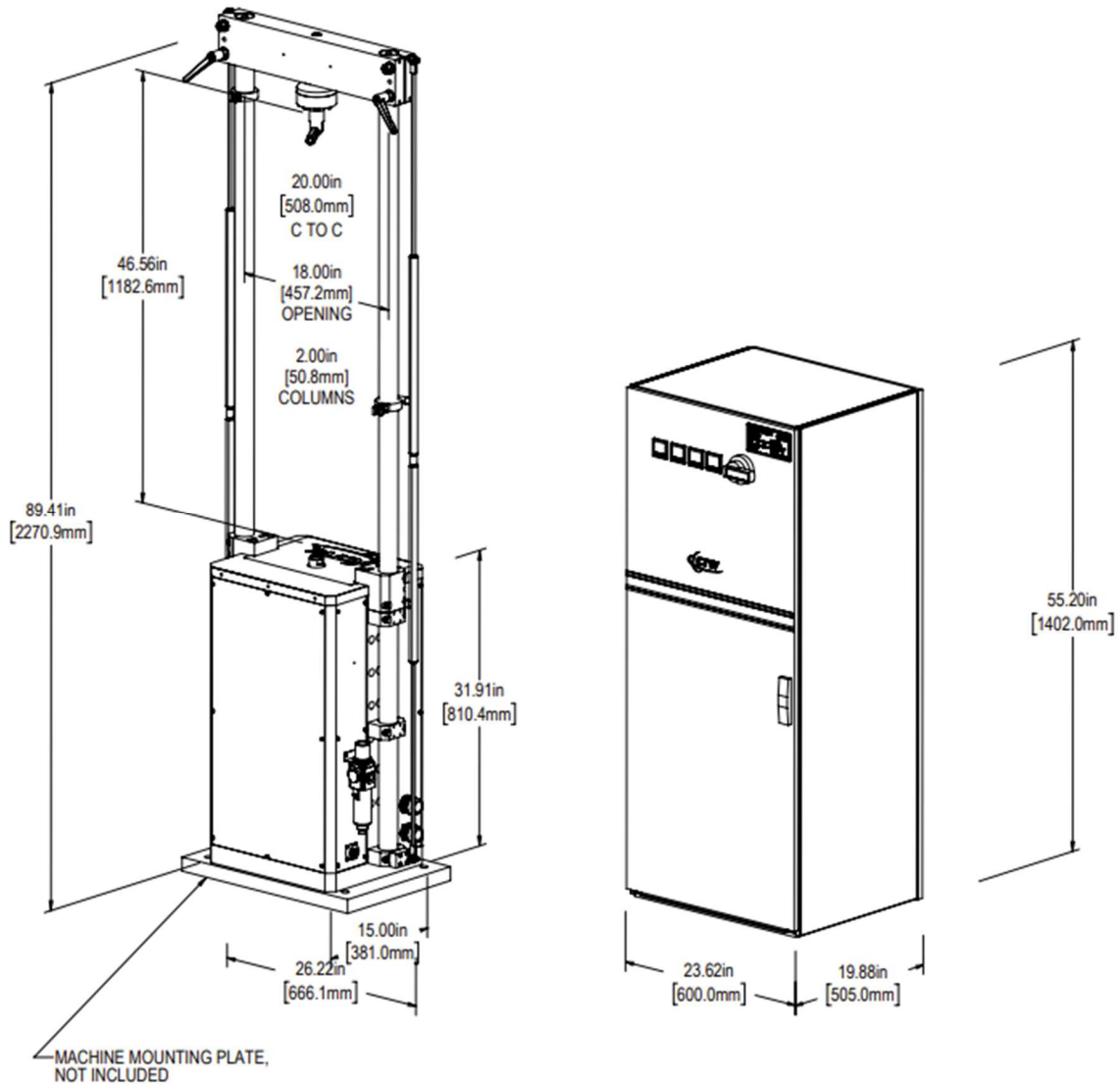

STANDARD COLUMNS - 60" / 1524mm

General Dimensional Outline of LA28 / LA48

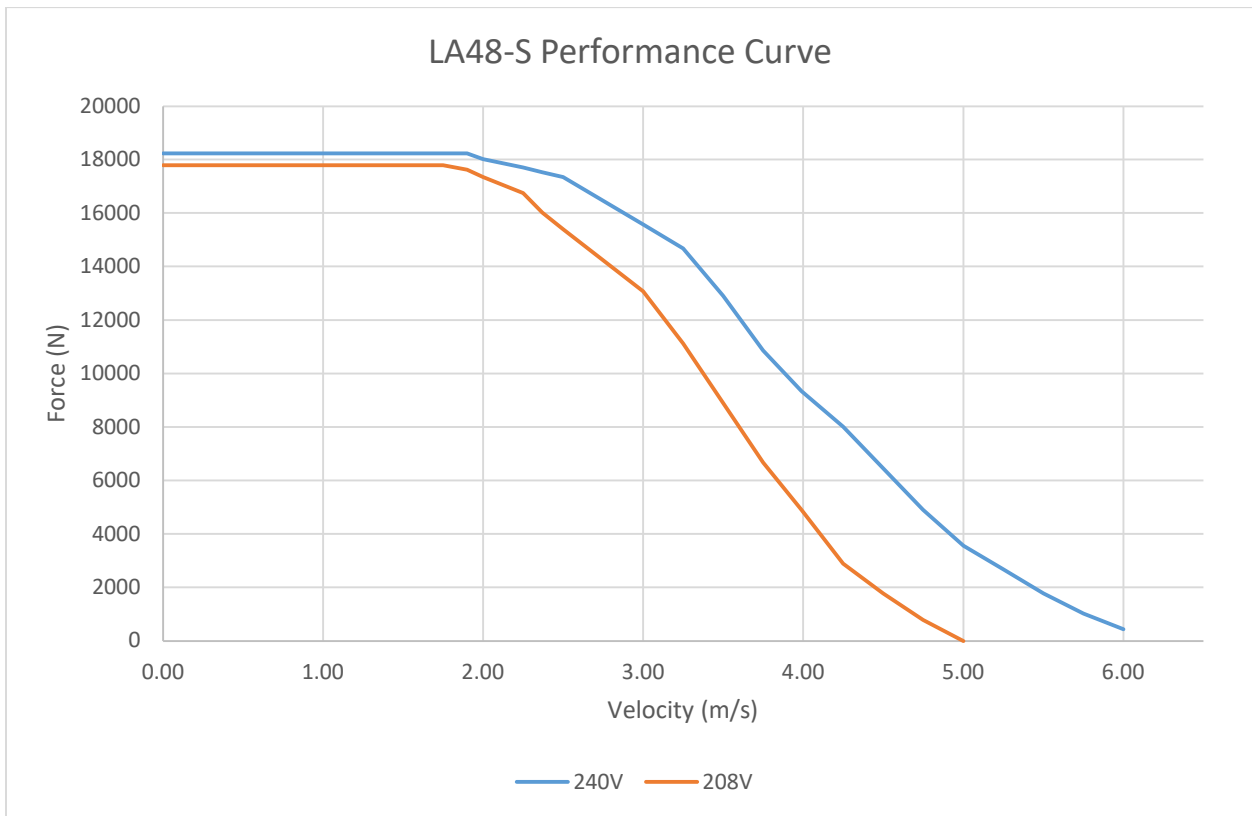
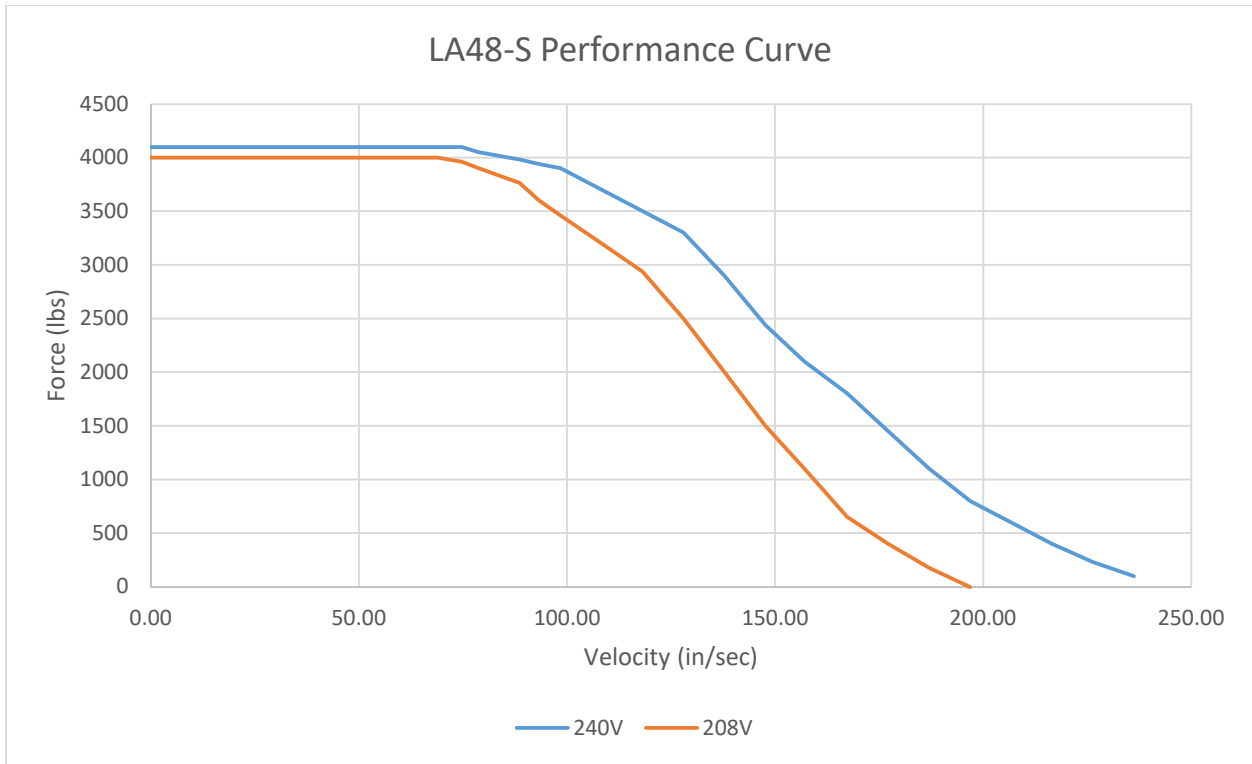

** Note: All data points are taken using a 3-inch displacement. Test machine is connected to 240VAC 3 phase input. Voltages lower than 240VAC 3 phase will result in decreased performance. Published specs are +/-10%.

General Options overview

NIST certified calibration: using traceable third-party equipment CTW can calibrate and certify the Displacement and Force sensors. This will include PDF documentation and applicable labels for the machine and serviceable time frame.

Fully automated crossbar – see below.

Analog Input ability – see below.

Enclosure 48/410 series - Aluminum extrusion w Lexan panels – Enclosure including hinged door latch. Fully enclosed 4 sides

CE compliance – This adds a complete power-off safety circuit to be used with Enclosure option. This CE option prevents the flow of power to the machine unless the CE circuit / door lock is satisfied. - Requires the addition of enclosure option.



Fully Automated Crossbar LA

Gas Strutt Assist crossbar LA

LA Series shown with cage / enclosure

Side Loading Addition - Apply constant force to the damper body (nonmoving) controlled thru CTW Probe software command using pneumatic cylinder. Available up to 225 lbs. / 1,000 N. The force is set before each Test or before each speed so that a constant force can be applied or changed or even removed per speed.



Analog Output controlled Side Loading device

Analog Out (Ver I) - Output of Displacement and Force using the CTW Probe Tracking feature. Signals sent out via BNC connectors or other industry standard to customer device.

Analog Out (Ver II) – Output voltage (+/- 10V) based on CTW Probe Command, discrete, between Test speeds

Dynamic Analog Out (II) – Using the custom wave form feature, User can create up to (4) outputs along with a custom wave form.

Digital IO (4 in / 4 out) - for supplying discrete On/Off signals during the Test sequence. The IO is driven by User commands within CTW Probe software. Includes interface for connection to external device (not included). These can signal devices to trigger a response or change.

Clevis Fixtures - CTW offers a wide variety of clevis fixtures for a range of dampers, forks and shocks ranging from car to motorcycle and even helicopter. We can also quote custom fixtures for your needs.

Crossbar Automation

The User will interface with the crossbar with the following keypad with access to various functions.

Note: Future versions will use a manual interface panel

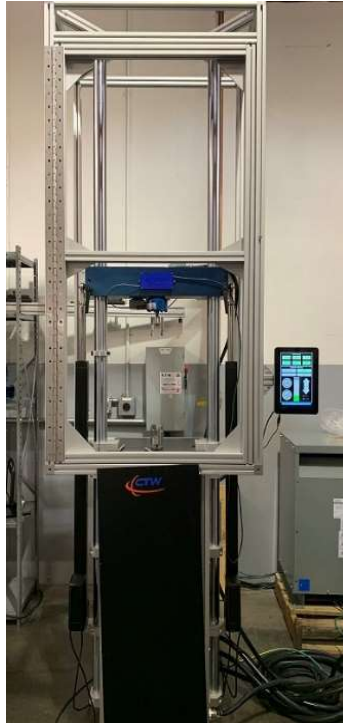

- Motor Temperature monitor with active integrated cooling limits
- Crossbar Status Indicator
 - Clamp / Release
 - Locked / unlock
- Crossbar Position with User defined “zero”
- Two-Speed control of movement
 - Fast for large travel adjustments
 - Slow for damper mounting
- 1000 mm range of movement
- 900 lbf. of force available to compress / extend the specimen / damper

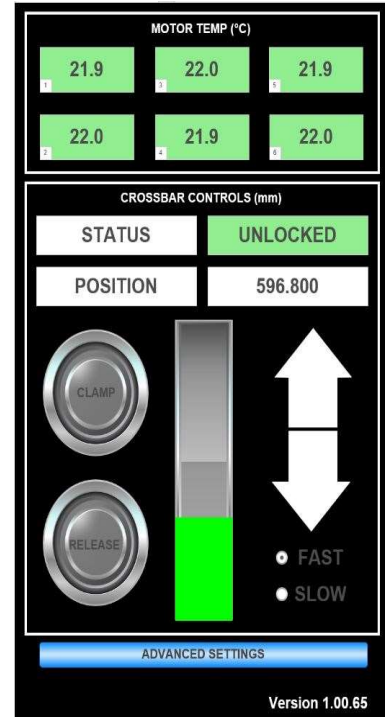

**Full
1000 mm
of travel**



Complete LA with Automated crossbar and Enclosure showing full system and 1000 mm range of travel

(6) Additional Channels

CTW Automation offers up to (6) additional channels for the User to collect signals beyond the standard offering for the machine. By creating an interface that is customizable per-channel, the User has the ability to customize for any given requirement and sensor.

Each channel uses its own board. These can be changed and/or switched out quickly to provide flexibility and customization.

Key features:

- 6 channels
- Simultaneous sample rate up to 4kHz
- Bridge Excitation/Signal Conditioning (regulated +/-10V or +/-20V) (load cells, strain gauges)
- Sensor signal conditioning: regulated +/-5V, 10V, 12V or +24V excitation. Switchable gain 1x, 2x, 4x, 10x
- Pass through: non-regulated +24V excitation, 1x gain, 4Khz anti-aliasing filter
- Can make custom boards upon request





Support Contract

CTW offers a full year of Support for your testing equipment and software. This Support contract allows for unlimited phone and e-mail help to the users of the machines so they can get fast and helpful answers to their questions and quickly resolve any problems they might have. It also includes support via remote access using Team Viewer and CTW's exclusive license. By registering your covered machines using their serial numbers, you are given a Support contract identifier to be used for all help.

This help includes:

- * software questions and help understanding how best to use it
- * fixing errors and general help to build Tests and change settings
- * help getting a new laptop up and running after a computer crash
- * training using the remote access feature
- * Team Viewer remote access for training, help and repair of software and connections on the go
- * CTW offers this for all Roehrig Engineering machines and software

System Files Support

Included in your contract, we will also save and host your System files and Settings files on our server so that we can help with any future computer crashes. Because we track all machines that we encounter, we keep records of them based on their serial numbers. By exporting your settings and e-mailing to us, we can keep a copy safe under your serial number so that when your computer dies, we can get you up and running quicker.