

LA613 – Linear Actuator – Specification Sheet

the LA613 by CTW Automation - (6) Motor (13) Inches of travel



LA613/618 - shown with optional enclosure / cage

LA613 - Key Specifications

- Fully Electric – Magnetic linear actuator for instant on motion and force
- Usable stroke range of 13 inches / 330 mm
- Peak force (using 240 VAC @ 100 Amps of 6,100 lbf. < > 27kN
 - 6,000 lbf. out to 80 in/sec < > 2.00 Met/sec
 - 400+ lbf. to 216 in/sec < > 5.50 Met/sec
 - Based on 240VAC power +/-2.5%
- Peak Velocity of 220 in/sec & 5.60 Met/sec
- Acceleration of 105+ G's peak & 30 G's continuous
- Frequency response above 175 Hz
- Optimized motion for cooler and quieter operation
- Includes complete Win10 operating system with computer and monitor
- Sine, Triangle, Split Velocity/ Variable Velocity, track data and more
- Input power 208-240 VAC III phase – 100/120 A **



The **LA Series** of actuators by CTW Automation is the ultimate in high performance linear motion that puts wave form creation and the resulting data collection at your fingertips; quickly, easily and in a repeatable fashion. While sine waves are standard, the LA allows for “any wave form” drive profiles allowing you to attain a better view into your testing world. From square, to triangle, sine on sine, frequency sweeps and stepped input; this platform lets you do it all. Additionally, updated motion control methodology allows CTW to deliver the requested wave form at a lower operating temperature and lower audible level.

Standard System Features:

Sensors and signals:

Displacement, Force and Temperature (via an infrared non-contacting sensor) are standard. **Velocity** is derived from Displacement giving (4) channels to be used in viewing the resulting data.

- Force / load is measure via Interface 10K Pancake design to ensure accurate and repeatable results with low noise rejection.
- Displacement comes from analog encoder of 1 nanometer resolution mounted to the actuator to deliver a true reading of motion in the vertical axis.
- Temperature is mounted on an easy to move, CTW custom quick clamp allowing the User to test any damper at a constant point helping to improve consistency in comparing dampers and changes.

Stroke:

The LA613 has a useable range of 13.00 inches & 330 mm as the maximum available movement is more thus allowing for a very usable stroke as well as additional travel outside the range.

Velocity:

The LA618 peak velocity is 220 in/sec & 5.5 Met/sec. Owners should expect a very useful 5.50 Met/sec peak operating velocity with minimal displacement error within a given force range.

Acceleration:

Due to extreme design considerations in moving mass the acceleration performance far exceeds the industry norms. Over 105+ G's can be achieved for peak while a constant 30 G's is usable for testing. The frequency response is well over 175 Hz at less than 3dB down.

Waveforms:

Wave forms include Sine, Triangle, and Variable Speed for separating compression and extension speeds. The User can also import drive files to replay displacement data from a track or event as well as white noise and other frequency generating wave forms.



Software:

By using a GUI based on Windows 10 application platform, you are ready to build your own Test sequences via command-based prompts that allow you to go from nothing to 200 Hz in a few moments. In standard configuration, the User has a wide variety of canned wave forms, logging and prompts to develop specific Tests for every given damper or test specimen.

Columns:

Columns are 2.50" diameter and standard length provides a test opening of 58.8" / 1490 mm from the end of the load cell stud to the top of the actuator. Longer columns can be purchased.

Power input:

The LA68/613/618 requires 208-240VAC III phase power minimum of 100 service A(i). Outside of North America, it is best to use a step-down transformer to go from 380/440 VAC III phase to the 240 VAC III. Power and controls are fed to the LA via a control cabinet interface.

** Note – for peak performance, three phase (III) –100 Amps (i) and a peak input voltage of 240 VAC MUST be supplied.

Training:

Training can be done on site or at Lexington facility. If CTW must travel, additional charges will result. Understand that the machine is done and ready when it leaves our dock so that it is possible to train in our facility knowing the machine will be easy to get running on site.

Support:

The LA613 comes with a 1 -Year phone and e-mail support contract as well as use of TeamViewer remote access ability for training and help. We want you to have every opportunity to use and get the most from the machine.

Warranty:

The LA613 comes with a 1 -Year limited warranty.

Delivery:

- Customer can opt to pick-up in Lexington, NC but then NC State tax applies
- Crate – (2)
 - By ground transport in Continental US
 - International air freight shipping is preferred

General Options overview

NIST certified calibration: using traceable third-party equipment CTW can calibrate and certify the Displacement and Force sensors. This will include PDF documentation and applicable labels for the machine and serviceable time frame.

Fully automated crossbar – see below.

Analog Input ability – see below.

Enclosure 613/618 series - Aluminum extrusion w Lexan panels – Enclosure including hinged door latch. Fully enclosed 4 sides

CE compliance – This adds a complete power-off safety circuit to be used with Enclosure option. This CE option prevents the flow of power to the machine unless the CE circuit / door lock is satisfied. - Requires the addition of enclosure option.



Fully Automated Crossbar LA

Gas Strutt Assist crossbar LA

LA Series shown with cage / enclosure

Side Loading Addition - Apply constant force to the damper body (nonmoving) controlled thru CTW Probe software command using pneumatic cylinder. Available up to 225 lbs. / 1,000 N. The force is set before each Test or before each speed so that a constant force can be applied or changed or even removed per speed.



Analog Output controlled Side Loading device

Analog Out (Ver I) – LIVE Output of Displacement and Force using the CTW Probe Tracking feature. Signals sent out via BNC connectors or other industry standard to customer device.

Analog Out (Ver II) – LIVE Output voltage (+/- 10V) based on CTW Probe Command, discrete, between Test speeds

Dynamic Analog Out (II) – LIVE using the custom wave form feature, User can create up to (4) outputs along with a custom wave form.

Digital IO (4 in / 4 out) - for supplying discrete On/Off signals during the Test sequence. The IO is driven by User commands within CTW Probe software. Includes interface for connection to external device (not included). These can signal devices to trigger a response or change.

Clevis Fixtures - CTW offers a wide variety of clevis fixtures for a range of dampers, forks and shocks ranging from car to motorcycle and even helicopter. We can also quote custom fixtures for your needs.

Automated Crossbar overview - Option

The User will interface with the crossbar with the following keypad with access to various functions.

Note: Future versions will use a manual interface panel

- Motor Temperature monitor with active integrated cooling limits
- Crossbar Status Indicator
 - Clamp / Release
 - Locked / unlock
- Crossbar Position with User defined “zero”
- Two-Speed control of movement
 - Fast for large travel adjustments
 - Slow for damper mounting
- 1000 mm range of movement
- 900 lbf of force available to compress / extend the specimen / damper



Crossbar Keypad Interface

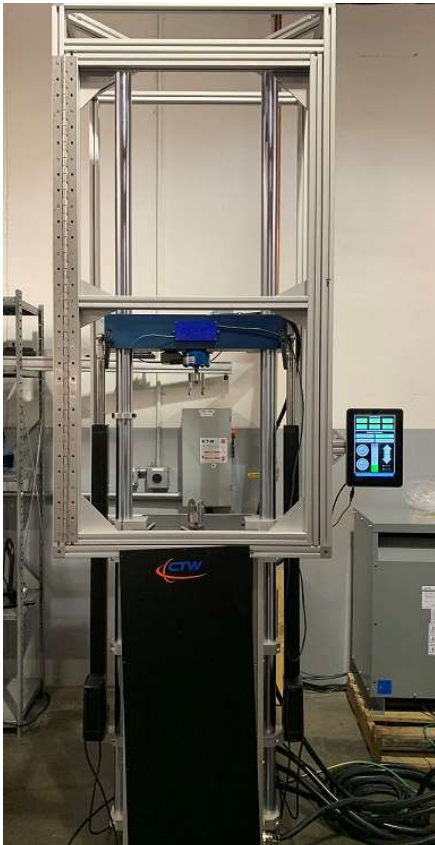

**Full
1000 mm
of travel**



**Complete LA with Automated crossbar and Enclosure
showing full system and 1000 mm range of travel**

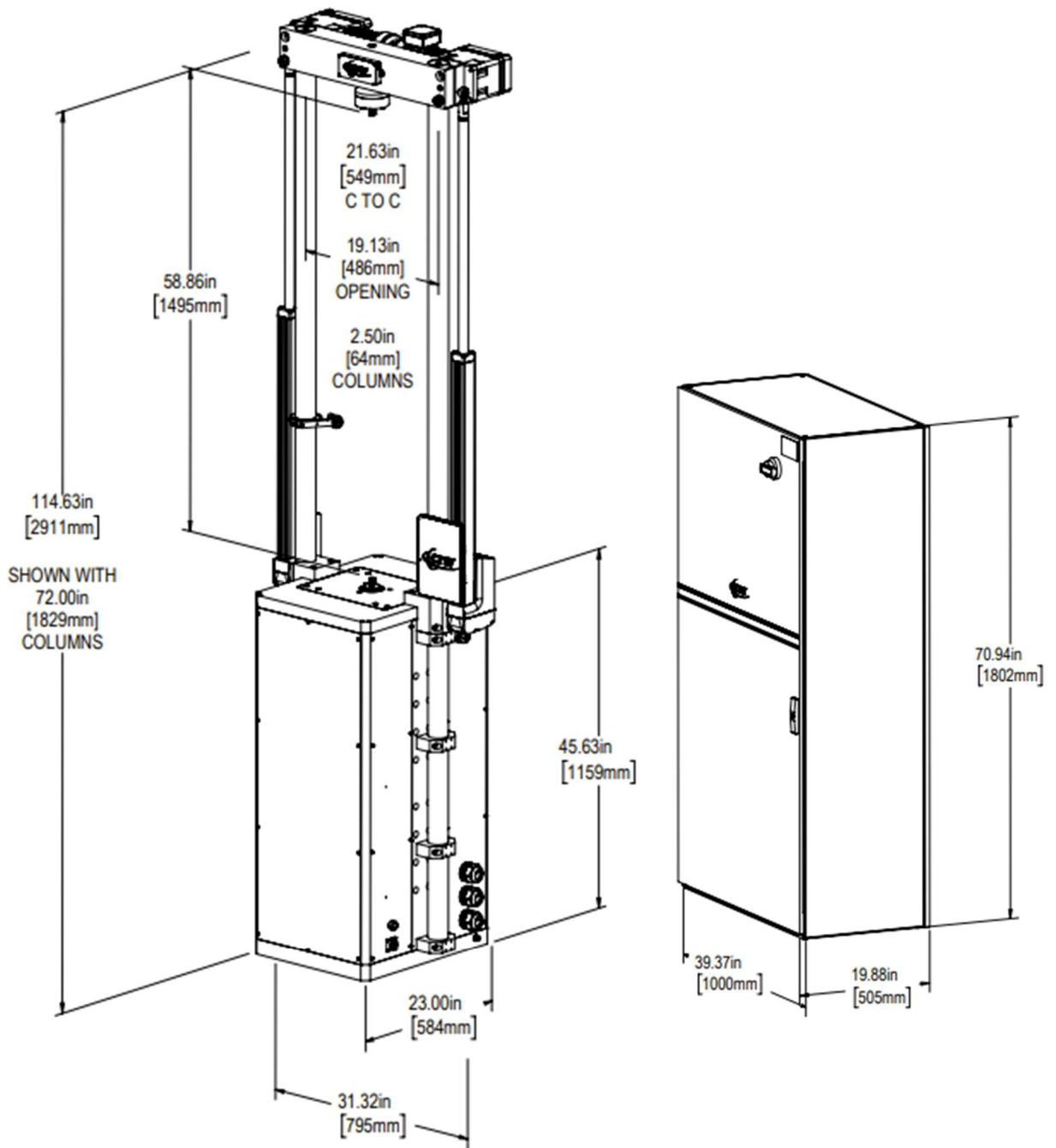

General Dimensional Outline of LA618

Option: 6 Additional Channel Input option

CTW Automation offers up to (6) additional channels for the User to collect signals beyond the standard offering for the machine. By creating an interface that is customizable per-channel, the User has the ability to customize for any given requirement and sensor.

Each channel uses its own board. These can be changed and/or switched out quickly to provide flexibility and customization.

Key features:

- 6 channels
- Simultaneous sample rate up to 4kHz
- Bridge Excitation/Signal Conditioning (regulated +/-10V or +/-20V) (load cells, strain gauges)
- Sensor signal conditioning: regulated +/-5V, 10V, 12V or +24V excitation. Switchable gain 1x, 2x, 4x, 10x
- Pass through: non-regulated +24V excitation, 1x gain, 4Khz anti-aliasing filter
- Can make custom boards upon request





Support Contract

CTW offers a full year of Support for your testing equipment and software. This Support contract allows for unlimited phone and e-mail help to the users of the machines so they can get fast and helpful answers to their questions and quickly resolve any problems they might have. It also includes support via remote access using Team Viewer and CTW's exclusive license. By registering your covered machines using their serial numbers, you are given a Support contract identifier to be used for all help.

This help includes:

- * software questions and help understanding how best to use it
- * fixing errors and general help to build Tests and change settings
- * help getting a new laptop up and running after a computer crash
- * training using the remote access feature
- * Team Viewer remote access for training, help and repair of software and connections on the go
- * CTW offers this for all Roehrig Engineering machines and software

System Files Support

Included in your contract, we will also save and host your System files and Settings files on our server so that we can help with any future computer crashes. Because we track all machines that we encounter, we keep records of them based on their serial numbers. By exporting your settings and e-mailing to us, we can keep a copy safe under your serial number so that when your computer dies, we can get you up and running quicker.